

Materiale: torniti in acciaio 11SMnPb37 (AVP)
 Trattamento superficiale: grezzi

Esecuzioni a richiesta:

- torniti acciaio 36SMnPb14 (PR80) bonificato
- con trattamento superficiale

Werkstoff: gedreht in Stahl 11SMnPb37 (AVP)
 Oberflächenbehandlung: blank/roh

Ausführungen auf Anfrage :

- Gedreht in Stahl 36SMnPb14 (PR80) vergütet
- Mit Oberflächenbehandlung

	D	s	h
M8		13	9,5
M10		17	12
M12		19	15
M14	M14x1,5	22	16
M16	M16x1,5	24	19
M18	M18x1,5	27	21
M20	M20x1,5	30	22
M22	M22x1,5	32	26
M24	M24x2	36	27
M27	M27x2	41	30
M30	M30x2	46	33
M33	M33x2	50	35
M36	M36x3	55	38
M39	M39x3	60	40
M42	M42x3	65	46
M45	M45x3	70	48
M48	M48x3	75	50
M52	M52x3	80	54
M56	M56x4	85	57

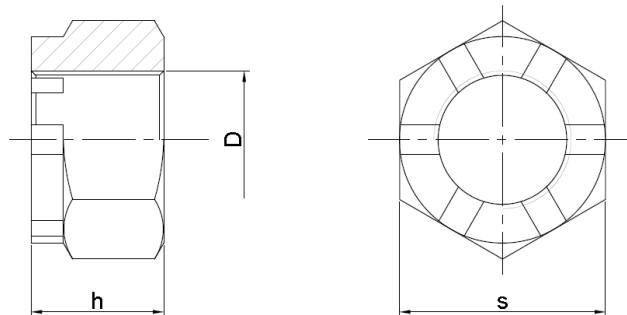

Materiale: torniti in acciaio 11SMnPb37 (AVP)
Trattamento superficiale: grezzi

Esecuzioni a richiesta:

- torniti acciaio 36SMnPb14 (PR80) bonificato
- con trattamento superficiale

Werkstoff: gedreht in Stahl 11SMnPb37 (AVP)
Oberflächenbehandlung: blank/roh

Ausführungen auf Anfrage :

- Gedreht in Stahl 36SMnPb14 (PR80) vergütet
- Mit Oberflächenbehandlung

	D	s	h
M8		13	8
M10		17	10
M12		19	12
M14	M14x1,5	22	13
M16	M16x1,5	24	14
M18	M18x1,5	27	15
M20	M20x1,5	30	15
M22	M22x1,5	32	18
M24	M24x2	36	18
M27	M27x2	41	20
M30	M30x2	46	21
M33	M33x2	50	23
M36	M36x3	55	23
M39	M39x3	60	25
M42	M42x3	65	28
M45	M45x3	70	30
M48	M48x3	75	30
M52	M52x3	80	32
M56	M56x4	85	37